

Une consultation préalable de A.Raymond SARL est nécessaire pour toute mise en place de la pièce en automatique.
Automatic processing of the part requires prior consultation with A.Raymond SARL.

VUE ISO

Ech. 1:1

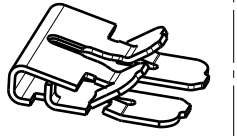

Détail C
Echelle : 6:1

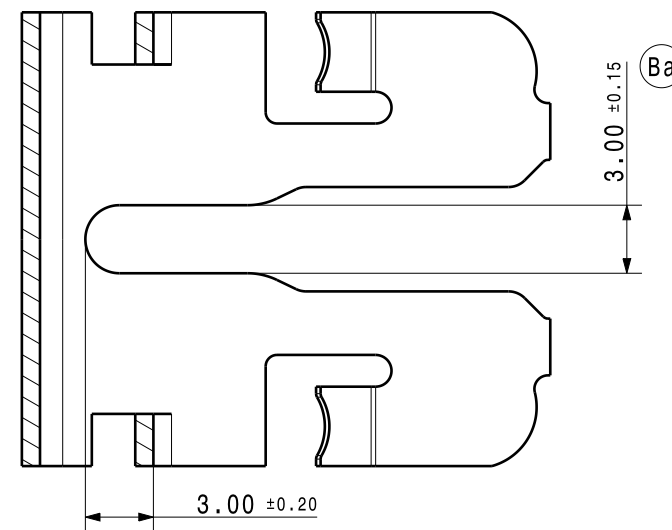
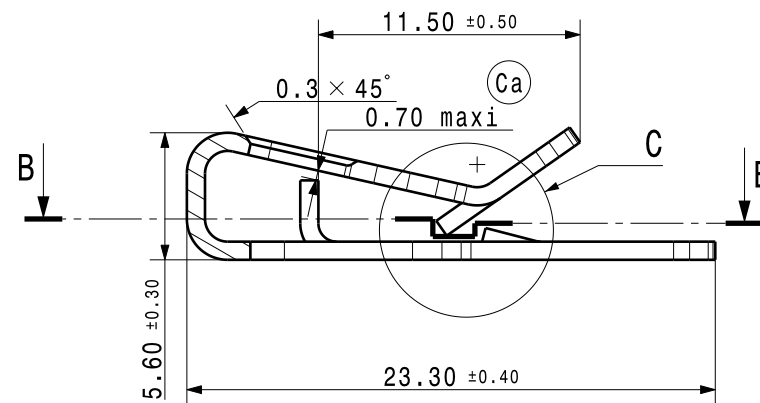
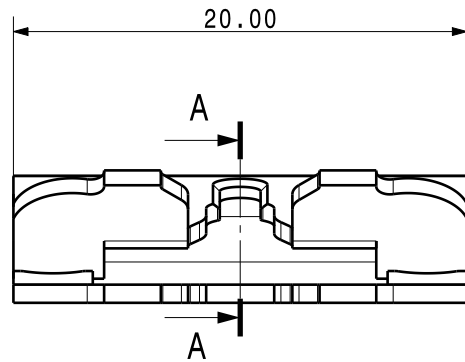
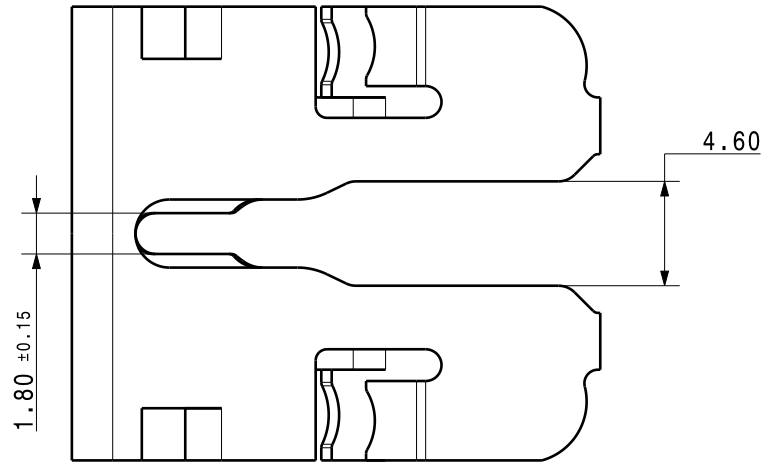
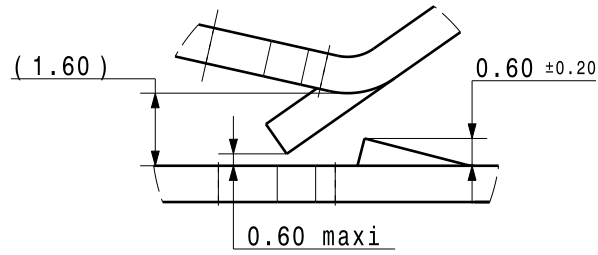

A.Raymond

113 cours Berriat BP 157
France - 38019 Grenoble cedex 1
Tel +33 (0) 4 76 33 49 49
Fax +33 (0) 4 76 78 20 50

Si problème de compréhension, merci de demander la version française à A.Raymond avant toute utilisation.

"CONDITIONS OF USE"

This drawing and all information (the "Drawings") disclosed are the exclusive property of A.Raymond. By using this Drawing the Addressee acknowledges and accepts that this Drawing (1) is covered by A.Raymond intellectual property rights or know-how and (2) is provided under the following conditions who represent a Deposit Agreement. This Drawing is for Addressee internal use only limited to its estimation. Without prior written consent of A.Raymond, no permission or rights for any purpose, is hereby granted, such as, without any limitation, (1) the copy, in part or entirely (2) and/or the presentation, in part or entirely, to any other third party outside the Addressee company or in the company but with no interest (3) and/or the distribution of the Drawings, in part or entirely, in any medium (4) and/or the creation of any derivative work. In case of breach of these conditions, Addressee shall indemnify A.Raymond from and against all damages (compensatory or consequential), costs, expenses and charges, caused or arising out of or attributable to its willful misconduct, fraud, negligence, infringement of A.Raymond Intellectual Property rights. If the Addressee does not accept these conditions, please notify A.Raymond sender immediately.

Brevets / Patent rights Classification code **XXXXX**

N° Projet / Project No. Origine / Origin **220492-9-Aa** Chef de projet / Project Manager

Echelle / scale **3:1** Format **A3** Tolerance / General tolerance Dimension Angle **± 0.50 ± 5.00°** Date **PAQUET.J**

ALL DIMENSIONS ARE IN MILLIMETERS Approuve / Approved **20120118083518** Epaisseur / Mat. thickness **0,80** Volume (mm³) **551,5** Poids / Weight (g) **4,3**

Finition / finish **Voir nota** Code finition finish code **-**

Traitement structural / Material treatment **C67S CR >0,5 : TTH.HR 30 N : 61,3 a 64,7 (42 a 46 HRc)**

Matiere / Material **C67S-A** Mat. code **-**

Libelle / Title **Produit spécifique Agrafe de mise à la terre Specific part**

Reference / Part no. **220492-0-00** Drawing type **C:Customer**

Ref. client / Customer part no. Planche / Sheet **1/1**

CAD system & version **CATIA V5 R19 SP3** Nom fichier / File name **220492-0C00**

Nota :
TDS : Depton 20 à 30 μ+ TNT

Conditions d'utilisation:

Agrafe de mise à la masse pour:
- câble 6mm² multibrin
- système avec surintensité maximale de 15 A
Se monte sur cadre aluminium suivant dessin ci-dessous :

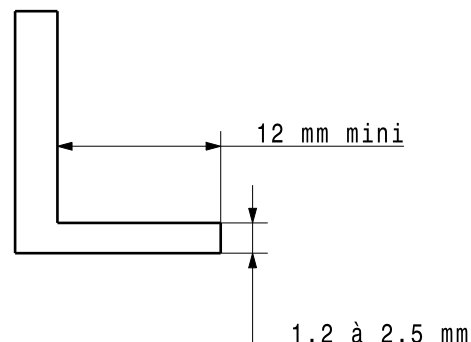

Ca	1	Modif longueur butée pour emblage	13.01.12	JPA
Ba	-	Modif découpe +supp chanfrein	27.10.11	JPA
Aa	-	version originale / initial release	23.06.11	SVA
REV.	Quant.	Indice / revision description	Date	Name

VERIFIER L ECHELLE APRES PHOTOCOPIE / BEWARE SCALE AFTER COPY

4
3
2
1

4
3
2
1